

FireStingO₂-Mini-ST

*OPTICAL OXYGEN OEM-MODULE
WITH UART-INTERFACE & ANALOG OUTPUT
FOR FIBER-OPTIC SENSORS*

MANUAL



The *FireStingO2-Mini-ST* is manufactured by

PyroScience GmbH
Hubertusstr. 35
52064 Aachen
Germany

Phone	+49 (0)241 5183 2210
Fax	+49 (0)241 5183 2299
Email	info@pyroscience.com
Internet	www.pyroscience.com

Registered: Aachen HRB 17329, Germany

TABLE OF CONTENT

1	INTRODUCTION	1
2	SAFETY GUIDELINES	2
3	OVERVIEW	4
3.1	OPTICAL PORT FOR OXYGEN SENSORS.....	4
3.2	SUPPLEMENTARY INTERNAL SENSORS.....	6
3.3	EXTERNAL TEMPERATURE SENSOR	7
4	ELECTRICAL CONNECTORS	9
4.1	CONNECTOR X1: POWER + DIGITAL INTERFACE.....	10
4.2	CONNECTOR X2: ANALOG OUTPUT	11
5	OPERATION VIA THE UART-INTERFACE	12
5.1	FULL-CONTROL MODE	12
5.2	AUTO-MODE.....	13
6	OPERATION VIA THE USB-INTERFACE CABLE.....	15
6.1	SOFTWARE INSTALLATION	15
6.2	USING THE PYRO OXYGEN LOGGER SOFTWARE.....	16
7	SPECIFICATIONS	18

1 Introduction

The *FireStingO₂-Mini-ST* is a high precision optical oxygen meter for liquid or gas samples, which is based on the opto-electronics of the successful USB-device *FireStingO₂* from *PyroScience*. Most features of the *FireStingO₂-Mini-ST* are identical to the *FireStingO₂*. Therefore, for a general introduction it is highly recommended to consult additionally the detailed manual of the *FireStingO₂*. Here we will cover mostly the differences of the *FireStingO₂-Mini-ST* compared to the *FireStingO₂*.

The *FSO₂-Mini-ST* is compatible to most oxygen sensors types available from *PyroScience*.

Further, it includes also internal high-precision sensors for (i) ambient atmospheric pressure, (ii) relative humidity of the ambient air, and (iii) the temperature of the ambient air. Additionally, an external temperature probe (PT100) used for automatic temperature compensation of the oxygen measurement can be soldered directly to the module (e.g. item *TSUB21-NC*).

This manual provides only specific information needed for the *FireStingO₂-Mini-ST*. It is highly recommended to study carefully the manual of the USB-device *FireStingO₂* in order to get a general introduction in optical oxygen measurements and the related sensor types.

2 Safety Guidelines

In order to guarantee an optimal performance of the *FireStingO2-Mini-ST* please follow these operation instructions and safety guidelines. If any problems or damage evolve, please disconnect the instrument immediately, mark it to prevent any further use and consult *PyroScience* for repair or maintenance service. The *FireStingO2-Mini-ST* should not be manipulated or opened by unauthorized persons (except for the needed steps in order to solder the external PT100 to the internal PCB-board), only by *PyroScience* or persons advised directly from *PyroScience*.

Please note that opening the housing (except removing the front cap for accessing the solder pads for the external temperature sensor) will void the warranty. There are no serviceable parts inside the device.

The *FireStingO2-Mini-ST* and the sensors should be kept and stored outside the reach of children in a secure place under dry and clean conditions at room temperature, avoiding moisture, dust, corrosive conditions and heating of the instrument. This device is not intended for medical, military or other safety relevant areas. It should be used in the laboratory by qualified personal only following the operation instructions and safety guidelines of this manual.

Please follow the appropriate laws and guidelines for safety like EEC directives for protective labor legislation, national protective labor legislation, safety regulations for accident prevention and safety data-sheets from manufacturer of chemicals used during measurements.

When used in the field, the environmental conditions (like high humidity, dust, exposure to direct solar radiation) may cause damage or interference of the *FireStingO2-Mini-ST*, which is on the user's authority.

Before using the *FireStingO2-Mini-ST* and its sensors, read carefully the instructions and user manuals.

In case of problems or damage, disconnect the instrument and mark it to prevent any further use! Consult *PyroScience* for advice! There are no serviceable parts inside the device. Please note that opening the housing will void the warranty!

The *FireStingO2-Mini-ST* is not watertight, is sensitive to corrosive conditions and to changes in temperature causing condensation. Avoid any condition (e.g. direct sun light) causing a heating of the device above 50°C (122°F).

Calibration and application of the sensors is on the user's authority, as well as data acquisition, treatment and publication!

The sensors and the oxygen meter *FireStingO2-Mini-ST* are not intended for medical, diagnostic, therapeutic, or military purposes or any other safety-critical applications. The sensors must not be used for applications in humans and must not be brought in direct contact with foods intended for consumption by humans.

The *FireStingO2-Mini-ST* and sensors should be used in the laboratory by qualified personnel only, following the user instructions and the safety guidelines of the manuals, as well as the appropriate laws and guidelines for safety in the laboratory!

Keep the sensors and the oxygen meter *FireStingO2-Mini-ST* out of reach of children!

3 Overview

Fig. 1 provides an overview of the *FSO₂-MINI-ST*. The overall dimension of the module is 67 x 25 x 25 mm (without the optical port). Two M₃ threads can be found at the bottom for mounting the module in customized setups. Please note, that one of the M₃ threads is hidden below the type label. The position of that M₃ thread is roughly indicated on the type label. Just penetrate the type label at this position with e.g. a needle or nail in order to access the M₃ thread.

3.1 Optical Port for Oxygen Sensors

The *FSO₂-MINI-ST* provides an ST-connector as known from the USB-device *FireStingO₂*. Thus, all optical oxygen sensors available for the *FireStingO₂* (e.g. needle-type sensors, robust probes, fibers for read-out of sensor spots, flow through cells, respiration vials) can be directly connected to the *FSO₂-MINI-ST*. Please refer to the manual of the *FireStingO₂* for further details.

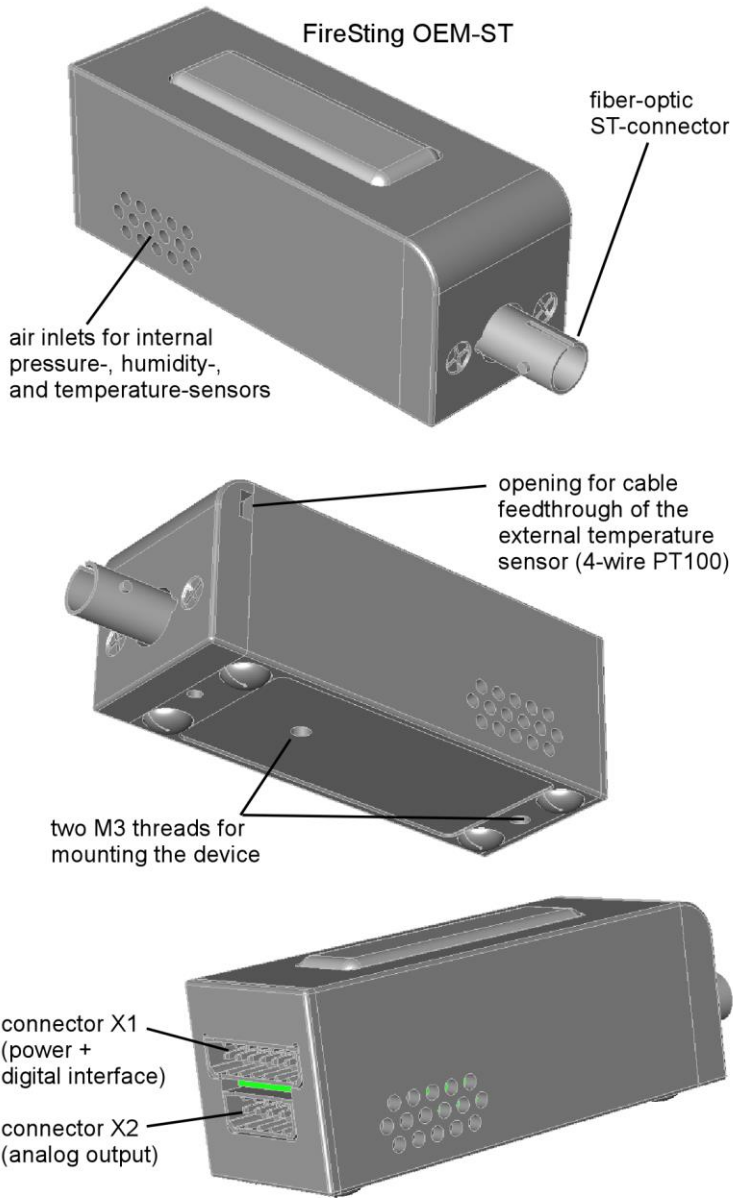

Fig. 1 Drawing of the FSO₂-MINI-ST

3.2 Supplementary Internal Sensors

Besides the very oxygen sensor, the *FireStingO2-Mini-ST* provides three other built-in high precision sensors:

- (1) An internal **atmospheric pressure sensor** for measuring the ambient air pressure,
- (2) an internal sensor for measuring the **relative humidity** of the ambient air, and
- (3) an **internal temperature sensor** measuring the temperature of the ambient air.

These three internal sensors are positioned within the module close to the air inlets on both sides of the housing. In order to get reliable data about the ambient air from these internal sensors, it is important to ensure free air access around the air inlets. The pressure and the humidity sensors will give in most situations reliable data about the ambient air. However, the readings of the internal temperature sensor should be interpreted more carefully. First, the internal heating by the electronics typically increases the internal temperature by about 1°C. This offset can get much worse, if the module is additionally exposed to e.g. strong illumination. It is on the user's authority to interpret the internal temperature sensor with care.

The internal humidity sensor can be useful if a simple air calibration of the oxygen sensor shall be performed in ambient air. For this calibration type the relative humidity of the ambient air has to be known, because the humidity changes the actual volume fraction of oxygen in the ambient air.

Similarly, the internal pressure sensor is generally useful for any air calibration performed under ambient air pressure, because the actual air pressure has to be known during the calibration. But the pressure sensor can be also used during the oxygen measurements

for automatic pressure compensation (useful for the following oxygen units: %air sat, %O₂, μmol/L, mg/L).

3.3 External Temperature Sensor

The oxygen measurement is generally temperature dependent. Therefore, the *FireStingO₂-Mini-ST* provides a built-in temperature compensation, which should be activated if the temperature changes during measurements more than ca. 1°C. Although under certain circumstances the internal temperature sensor can be also utilized for such a compensation, the first choice should be always an external 4-wire PT100 temperature sensor placed directly within the sample where the oxygen concentration is measured. The *FireStingO₂-Mini-ST* provides a high-precision sensor interface which can be directly connected to any standard 4-wire PT100.

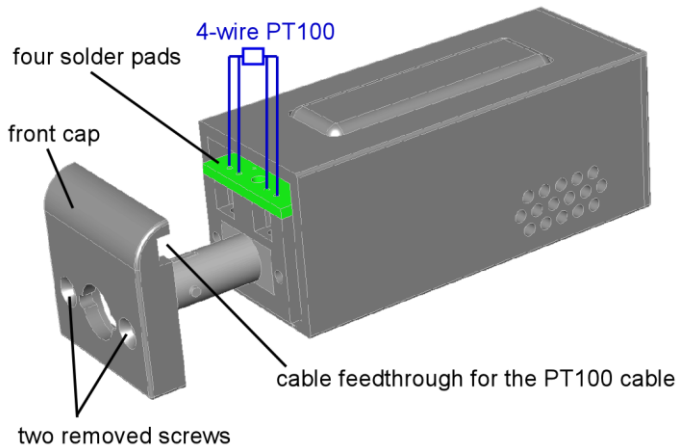

Fig. 2 Connecting a 4-wire PT100 temperature sensor to the OEM module

The PT100 has to be soldered directly to the electronics board within the module. In order to access the solder pads, the front cap of the housing has to be removed by unscrewing the two screws besides the optical port. Please refer to Fig. 2 how to connect the

4-wire PT100. The front cap provides a small cable feedthrough where the cable of the external PT100 can penetrate the housing. When closing the housing again, ensure that the solder points do not get into contact to the aluminum housing.

NOTE: In order to minimize potential electrical noise coupling into the external temperature sensor, the 4-wire cable should be twisted and as short as possible. Cable lengths above 2m are not recommended. For minimizing any noise further, the 4-wire cable can be provided with an additional coaxial shield, which has to be connected to ground.

4 Electrical Connectors

The electrical interface of the *FireStingO2-Mini-ST* consists of the two connectors X1 and X2 (Fig. 1). The package includes for both connectors the connector plugs S1 and S2, also available from "Phoenix Contact" item no. 1778887 and 1778861 (Fig. 3). Stripped cable ends can be connected to S1 and S2 without any soldering or crimping. When inserting or removing a stripped cable end (stripping length 6 mm, max. core diameter 0.5 mm²) into one of the connector holes of the connectors S1 or S2, an internal spring mechanism has to be unlocked by pushing relatively strong with a small screw-driver (flat-bladed 2mm in width) into the adjacent rectangular hole (Fig. 3). Please note that pin 1 of the connectors is positioned always at the right side of the connector (Fig. 3).

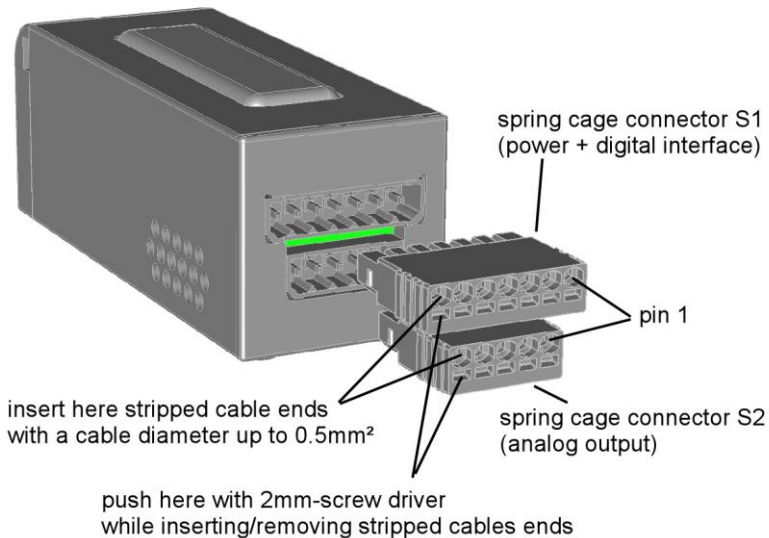

Fig. 3 Electrical connectors of the *FireStingO2-Mini-ST*

4.1 Connector X1: Power + Digital Interface

The pin configuration of the connector X1 is given in Tab. 1. Pins 1-3 are for power supply of the module. The transmit and receive pins of the UART-interface are given at pins 4+5. The additional pins 6+7 are only needed if the module should be operated in auto-mode (see following chapter). In standard operation mode both pins 6+7 should be left unconnected.

Pin	Name	Function	Description
1	GND	Power	Ground
2	VCC	Power	Power supply min. 3.5V max. 5.0V DC max. 50 mA (typical 30 mA)
3	GND	Power	Ground
4	TXD	Digital Output (0V or 3.3V)	Data transmission pin of the UART interface
5	RXD	Digital Input (0V or 3.3V) (5V tolerant)	Data receive pin of the UART interface
6	/AUTO	Digital Input (0V or 3.3V, internally pulled- up to 3.3V)	Leave auto-mode pin unconnected for normal operation. Connect to GND for auto-mode operation.
7	/TRIG	Digital Input (0V or 3.3V, internally pulled- up to 3.3V)	Trigger input for triggering a measurement in "triggered auto-mode". The trigger is activated at the moment, when the unconnected pin is tied to GND.

Tab. 1 Pin configuration of the connector X1

4.2 Connector X2: Analog Output

The connector X2 provides 4 independent analog outputs with a range of 0-2.5V DC at a resolution of 14 bits (Tab. 2). The 4 analog outputs can be configured by the UART communication protocol very flexible. The parameter given at each analog output can be chosen (e.g. oxygen concentration in different units, signal intensity of the oxygen sensor, ambient pressure, ambient humidity, internal temperature, external temperature from PT100), the scaling can be adjusted freely, and even an alarm function can be configured. If an analog output is configured as an alarm output, it will give 2.5V if a specific parameter is out of a defined range (and 0V if it is within this range).

For further details please refer to the separately available communication protocol.

Pin	Name	Function	Description
1	GND		Ground
2	AO_A	Analog Output (0 – 2.5 V DC) (14 bit resolution)	Analog Output Port A (alternatively digital alarm output)
3	AO_B	Analog Output (0 – 2.5 V DC) (14 bit resolution)	Analog Output Port B (alternatively digital alarm output)
4	AO_C	Analog Output (0 – 2.5 V DC) (14 bit resolution)	Analog Output Port C (alternatively digital alarm output)
5	AO_D	Analog Output (0 – 2.5 V DC) (14 bit resolution)	Analog Output Port D (alternatively digital alarm output)

Tab. 2 Pin configuration of the connector X2

5 Operation via the UART-Interface

The *FireStingO2-Mini-ST* is operated via a standard UART interface at 3.3V levels (5V tolerant) consisting merely of a receive and a transmit line (connector X1, pins 4+5, see Tab. 1). The configuration of the UART-interface is as follows:

19200 baud, 8 data bit, 1 stop bit, no parity, no handshake

The baud rate can be changed by a special command of the communication protocol (refer to the communication protocol for further information). However, after power cycling the module always reverts to the standard baud rate of 19200.

There are two principal operation modes possible: (1) the full-control mode and the (2) auto-mode. Please note that adjusting the settings and performing any calibration can only be done in the full-control mode.

5.1 Full-Control Mode

The standard operation mode of the module is the full-control mode. The necessary electrical connections are shown in Fig. 4.

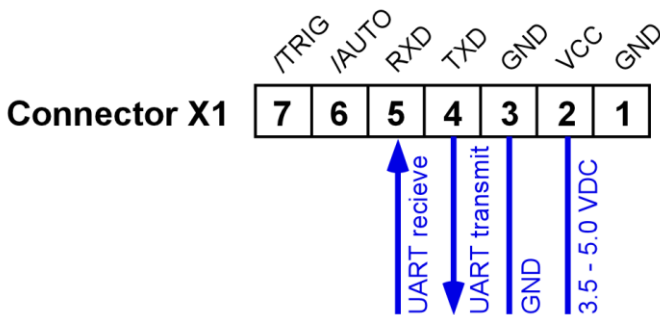

Fig. 4 Pin assignment in full-control mode

The full-control mode allows exploiting the full functionality of the module. Each action of the module is triggered by transmitting a

text-command via the UART interface. The measurement results can be either read out via the same UART interface. Alternatively, measurement results can be also read from the analog output.

For further details please refer to the separately available communication protocol.

5.2 Auto-Mode

In the full-control mode each single measurement has to be triggered by a specific command sent via the UART interface (e.g. the MSR- or TMP-commands for measuring oxygen or temperature, respectively). Alternatively, an auto-mode can be activated by connecting pin 6 of connector X1 to ground (Fig. 5).

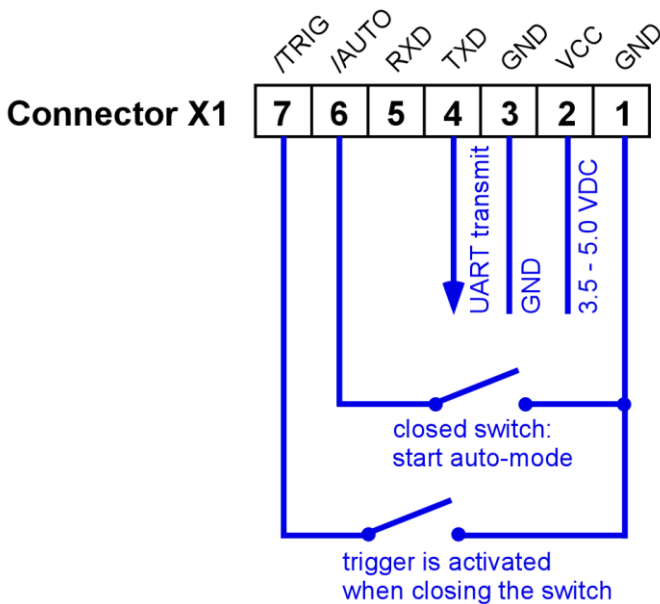

Fig. 5 Pin assignment in auto-mode

The auto-mode offers the possibility, (i) that the measurements are automatically triggered periodically by an internal timer (interval auto-mode) or (ii) that the measurements are triggered

each time when pin 7 of connector X1 is tied to ground (triggered auto-mode). The results of the measurements can be either read from the transmit pin of the UART interface, or from the analog outputs at connector X2.

NOTE: When the auto-mode is activated, the receive pin of the UART interface has no function. The module will not respond to any command sent to it.

The basic idea behind the auto-mode is that a fully configured and calibrated module can be operated without the need of complex communication protocols. However, the configuration (including the configuration of the auto-mode!) and the calibration data have to be adjusted in the full-control mode (or by using the USB-interface cable in combination with the comfortable windows software *Pyro Oxygen Logger*; please refer to the next chapter). The communication protocol offers a special command for storing the current configuration and calibration data permanently in the internal flash memory. Thus, a fully configured module can be operated in auto-mode even if the power supply is intermediately interrupted.

A typical application scenario would be the following: the *FireStingO2-Mini-ST* could be configured and calibrated in a "calibration lab" using the full-control mode (or the windows software *Pyro Oxygen Logger*). The configuration and the calibration data are stored in the internal flash memory. Then the sensor is brought to the "field application" which can be a remote place. By connecting pin 6 of the connector X1 to ground the module starts measuring without the need of any UART communication. The measurement results can be read out from the analog output (or from a text-string sent via the UART transmit line).

For further details please refer to the separately available communication protocol.

6 Operation via the USB-Interface Cable

For the operation of the *FireStingO2-Mini-ST* with a usual Windows PC, the USB-interface cable *FSO2-MINI-USB* is available from *PyroScience*. It includes a license for the comfortable oxygen logger software *Pyro Oxygen Logger*. Especially for initial testing purposes this logger software can speed up OEM-developments significantly. All special features (including the analog output and the configuration of the auto-mode) of the *FireStingO2-Mini-ST* can be configured in an intuitive user interface. Additionally, the USB-interface cable *FSO2-MINI-USB* provides also a virtual COM-port. Custom Windows-software can use this virtual COM-port for communicating directly with the module based on the communication protocol corresponding to the full-control mode described in the previous chapter.

6.1 Software Installation

System requirements: PC with Windows 7/8/10 and min. 700 MB free disk space.

IMPORTANT: Do not connect the USB-interface cable *FSO2-MINI-USB* to your PC before the *Pyro Oxygen Logger* software has been installed. The software will install automatically the appropriate USB-drivers.

Installation steps:

- download the installer package and the manual for the newest version of the *Pyro Oxygen Logger* software from the *PyroScience* homepage:
www.pyroscience.com/downloads.html
- unzip and start the installer and follow the instructions

- after the successful installation a new program group "Pyro Oxygen Logger" is added to the start menu, and a short-cut named "Oxygen Logger" can be found on the desktop
- connect one end of the USB-interface cable *FSO₂-MINI-USB* to the connector X₁ of the *FireStingO₂-Mini-ST*
- connect the other end to an USB-port of the PC. The optical port of the *FireStingO₂-Mini-ST* should flash shortly, indicating the correct startup of the *FireStingO₂-Mini-ST*
- start the *Pyro Oxygen Logger* software.

6.2 Using the Pyro Oxygen Logger software

IMPORTANT: The following instructions are only valid for the versions ≥ 3.200 of the *Pyro Oxygen Logger* software. If you have an older version, please download and install the newest version.

Please refer to the manual provided with the software for general operation instructions.

In combination with OEM-applications it is important to know, that the actual logger settings and the calibration data are automatically saved in the internal flash memory of the *FireSting* device, each time the logger software is closed. A typical scenario for OEM-applications would be, that the USB-interface cable *FSO₂-MINI-USB* in combination with the *Pyro Oxygen Logger* software is used for configuring all settings and to calibrate the connected oxygen sensor. This is done in the settings and the calibration window, respectively.

If also the auto-mode should be configured, press within the settings window the button **Prepare Auto-Mode...** (simple settings, only for "interval auto-mode") or **Advanced Auto-**

Mode... (advanced settings, allowing also "triggered auto-mode") and configure the auto-mode in the respective dialog windows.

Such a configured module can be now used in several ways. The simplest way would be to operate the module in the auto-mode (see previous chapter). But even for using it in an OEM-application under the full-control mode can make sense, because the communication protocol for simply triggering the measurements and for reading the results is much more straightforward to implement, compared to implementing the configuration of all settings and calibration data.

7 Specifications

General Specifications	
Dimensions	67 x 25 x 25 mm (without the optical port)
Weight	70 g
Interface	UART (3.3V level, 5V tolerant)
Power Supply	min. 3.5 V max.5.0V DC max. 50 mA (typical 30 mA)
Operating temperature	0 to 50°C
Storage temperature	-20 to 70°C
Max. relative humidity	Non-condensing conditions
Oxygen Sensor	
Oxygen measuring principle	lifetime detection of REDFLASH indicator luminescence
Oxygen channel connector	fiber-optic ST-plug of <i>FireStingO₂-Mini-ST</i>
Excitation wavelength	620 nm (orange-red)
Detection wavelength	760 nm (near infrared)
Max. sample rate	ca. 20 samples per second (ext. temperature sensor not activated) ca. 4 samples per second (ext. temperature sensor activated)
For further specifications of the oxygen sensors refer to the separately available specifications for the connected oxygen sensor	
External Temperature Sensor	PT100 (not included)

Connection	Twisted 4-wire cable, max. 2m in length (optional with coaxial shielding connected to ground)
Resolution	0.02°C
Accuracy	±0.2°C
Range	-30 to 150°C
Internal Temperature Sensor	
Resolution	0.01°C
Accuracy	±0.3°C
Range	-40 to 125°C
Response Time	ca. 1 minute
Internal Humidity Sensor	
Resolution	0.04% rel. humidity
Accuracy	typ. ±0.2% rel. humidity
Range	0 to 100% rel. humidity
Response Time (t63%)	ca. 10 s
Internal Pressure Sensor	
Resolution	0.06 mbar (hPa)
Accuracy	typ. ±3 mbar (hPa)
Range	300 to 1100 mbar (hPa)
Response Time	Instant
Analog Outputs	
Resolution	0.15 mV
Accuracy	typ. ±0.3 mV
Range	0 to 2500 mV